

DESIGN NOTES

Active Voltage Positioning Reduces Output Capacitors

Design Note 224

Robert Sheehan

INTRODUCTION

Power supply performance, especially transient response, is key to meeting today's demands for low voltage, high current microprocessor power. In an effort to minimize the voltage deviation during a load step, a technique that has recently been named "active voltage positioning" is generating substantial interest and gaining popularity in the portable computer market. The benefits include lower peak-to-peak output voltage deviation for a given load step, without having to increase the output filter capacitance. Alternatively, the output filter capacitance can be reduced while maintaining the same peak-to-peak transient response.

BASIC PRINCIPLE

The term "active voltage positioning" (AVP) refers to setting the power supply output voltage at a point that is dependent on the load current. At minimum load, the output voltage is set to a slightly higher than nominal level. At full load, the output voltage is set to a slightly lower than nominal level. Effectively, the DC load regulation is degraded, but the load transient voltage deviation will be significantly improved. This is not a new idea, and it has been observed and described in many articles. What is new is the application of this principle to solve the

problem of transient response for microprocessor power. Let's look at some numbers to see how this works.

Assume a nominal 1.5V output capable of delivering 15A to the load, with a $\pm 6\%$ ($\pm 90\text{mV}$) transient window. For the first case, consider a classic converter with perfect DC regulation. Use a 10A load step with a slew rate of $100\text{A}/\mu\text{s}$. The initial voltage spike will be determined solely by the output capacitor's equivalent series resistance (ESR) and inductance (ESL). A bank of eight $470\mu\text{F}$, $30\text{m}\Omega$, 3nH tantalum capacitors will have an $\text{ESR} = 3.75\text{m}\Omega$ and $\text{ESL} = 375\text{pH}$. The initial voltage droop will be $(3.75\text{m}\Omega \cdot 10\text{A}) + (375\text{pH} \cdot 100\text{A}/\mu\text{s}) = 75\text{mV}$. This leaves a 1% margin for set point accuracy. The voltage excursion will be seen in both directions, for the full load to minimum load transient and for the minimum load to full load transient. The resulting deviation is $2 \cdot 75\text{mV} = 150\text{mV}$ peak-to-peak (Figure 2a).

Now look at the same transient using active voltage positioning. At the minimum load, purposefully set the output 3% (45mV) high. At full load, the output voltage will be set 3% low. During the minimum load to full load transient, the output voltage starts 45mV high, drops 75mV initially, and then settles to 45mV below nominal. For the full load to minimum load transient, the output

LTC and LT are registered trademarks of Linear Technology Corporation.

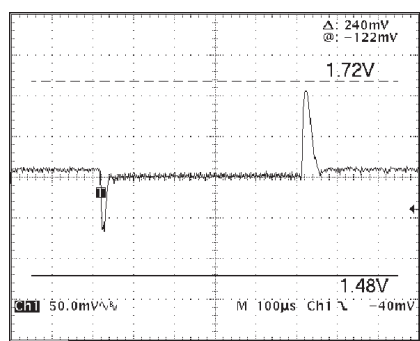

(1a) Without AVP – 4 Output Capacitors

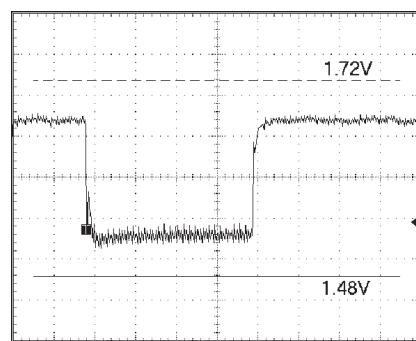

(1b) With AVP – 3 Output Capacitors

Figure 1. Transient Response with Load Step from 0A to 12A

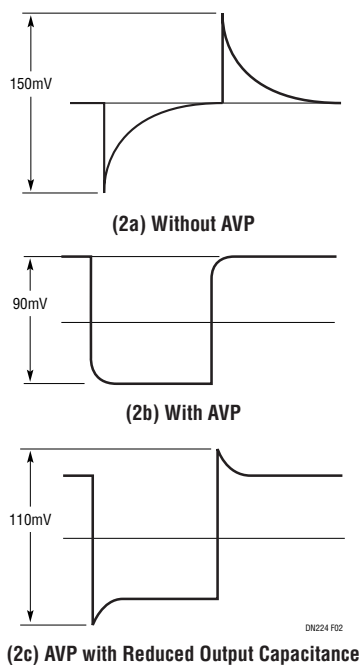

Figure 2. Transient Response Comparison

voltage starts 45mV low, rises 75mV to 35mV above nominal, and settles to 45mV above nominal. The resulting deviation is now only $2 \cdot 45\text{mV} = 90\text{mV}$ peak-to-peak (Figure 2b). Now reduce the number of output capacitors from eight to six. The $\text{ESR} = 5\text{m}\Omega$ and $\text{ESL} = 500\text{pH}$. The transient voltage step is now $(5\text{m}\Omega \cdot 10\text{A}) + (500\text{pH} \cdot 100\text{A}/\mu\text{s}) = 100\text{mV}$. With the 45mV offset, the resultant change is $\pm 55\text{mV}$ around center, or 110mV peak-to-peak (Figure 2c). The initial specification has been easily met with a 25% reduction in output capacitors.

An added benefit of voltage positioning is an incremental reduction in CPU power dissipation. With the output voltage set to 1.50V at 15A, the load power is 22.5W. By decreasing the output voltage to 1.47V, the load current is 14.7A and the load power is now 21.6W. The net saving is 0.9W.

BASIC IMPLEMENTATION

In order to implement voltage positioning, a method for sensing the load current is required. This information must then be used to move the output voltage in the correct direction. For a current mode controller, such as the LTC1736, a current sense resistor is already used. By controlling the error amplifier gain, we can achieve the desired result.

CURRENT MODE CONTROL EXAMPLE – LTC®1736

Figure 3 shows the basic power stage and feedback compensation circuit for the LTC1736. In a non-AVP implementation, R_{A1} and R_{A2} are removed and C_C and R_C installed. The corresponding transient response with 20V input and 1.6V output is shown in Figure 1a. In order to implement voltage positioning, we will control the error amplifier gain at the I_{TH} pin. The internal g_m amplifier gain is equal to $g_m \cdot R_O$, where g_m is the transconductance in mmhos, and R_O is the output impedance in kohms. The voltage at the I_{TH} pin is proportional to the load current, where $0.48\text{V} = \text{min load}$, $1.2\text{V} = \text{half load}$, and $2\text{V} = \text{full load}$ in this application. $R_O = 600\text{k}\Omega$ and $g_m = 1.3\text{mmho}$. By setting a voltage divider to 1.2V from the 5V INTV_{CC} , the gain can be limited without effecting the nominal DC set point at half load. The Thevenin equivalent resistance is seen to be in parallel with the amplifiers R_O . Using the values shown in Figure 3 for R_{A1} and R_{A2} , the effective R_O will be $600\text{k} \parallel 91\text{k} \parallel 27\text{k} = 20.12\text{k}\Omega$. The voltage deviation at the amplifier input $\Delta V_{FB} = \Delta V_{I_{TH}} / (g_m \cdot R_{O\text{eff}})$. $\Delta V_{FB} = (2.0\text{V} - 0.48\text{V}) / (1.3\text{mmho} \cdot 20.12\text{k}\Omega) = 58\text{mV}$, which is $\pm 29\text{mV}$ from the nominal half load set point.

Care should be taken to keep the amplifier input from being pulled more than $\pm 30\text{mV}$ from its nominal value, or non-linear behavior may result. The DC reference voltage at V_{FB} is 0.8V and V_{OUT} is set for 1.6V, so $\Delta V_{OUT} = 2 \cdot \Delta V_{FB} = 116\text{mV}$. The resulting transient response is shown in Figure 1b. The transient performance has been improved, while using fewer output capacitors.

The optimal amount of AVP offset is equal to $\Delta I \cdot \text{ESR}$. Figure 1b exhibits this condition.

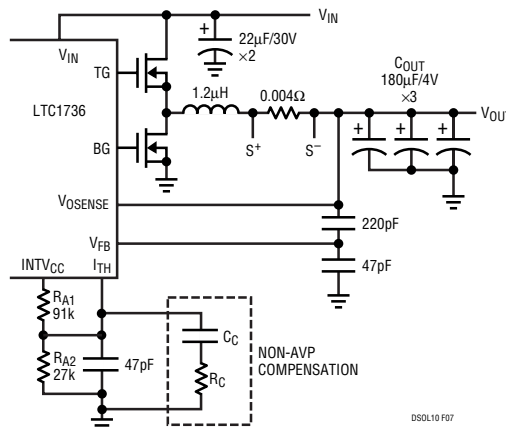

Figure 3. LTC1736 with AVP

dn234f LT/TP 1199 36K • PRINTED IN THE USA

LINEAR
TECHNOLOGY
© LINEAR TECHNOLOGY CORPORATION 1999

LTKK Japan-Tokyo
Tel: +81 (3) 3267-7891
FAX: +81 (3) 3267-8510
ltcjapan@a1.mbn.or.jp

LTKK Japan-Osaka
COMING SOON!

LTPL Hong Kong/PRC
Tel: +852 2428-0303
FAX: +852 2348-0885
echoli@ctimail.com

LTC Korea
Tel: +82 (2) 792-1617
FAX: +82 (2) 792-1619
ltckorea@nuri.net

LTPL Singapore
Tel: +65 753-2692
FAX: +65 754-4113
ltsg@pacific.net.sg

LTC Taiwan
Tel: +886 (2) 2521-7575
FAX: +886 (2) 2562-2285
ltcwn@ms12.hinet.net